

PART C4 : SITE INFORMATION

C4.1 : PROJECT LOCALITY

Capricorn Park is located within the jurisdiction of Molemole Local Municipality (MLM), in the town of Morebeng, North East of Polokwane in Limpopo Province.

The geographical co-ordinates of the site are Longitude (E): 29°55'06" and Latitude (S): 23°28'85" .

Please find locality plan below:

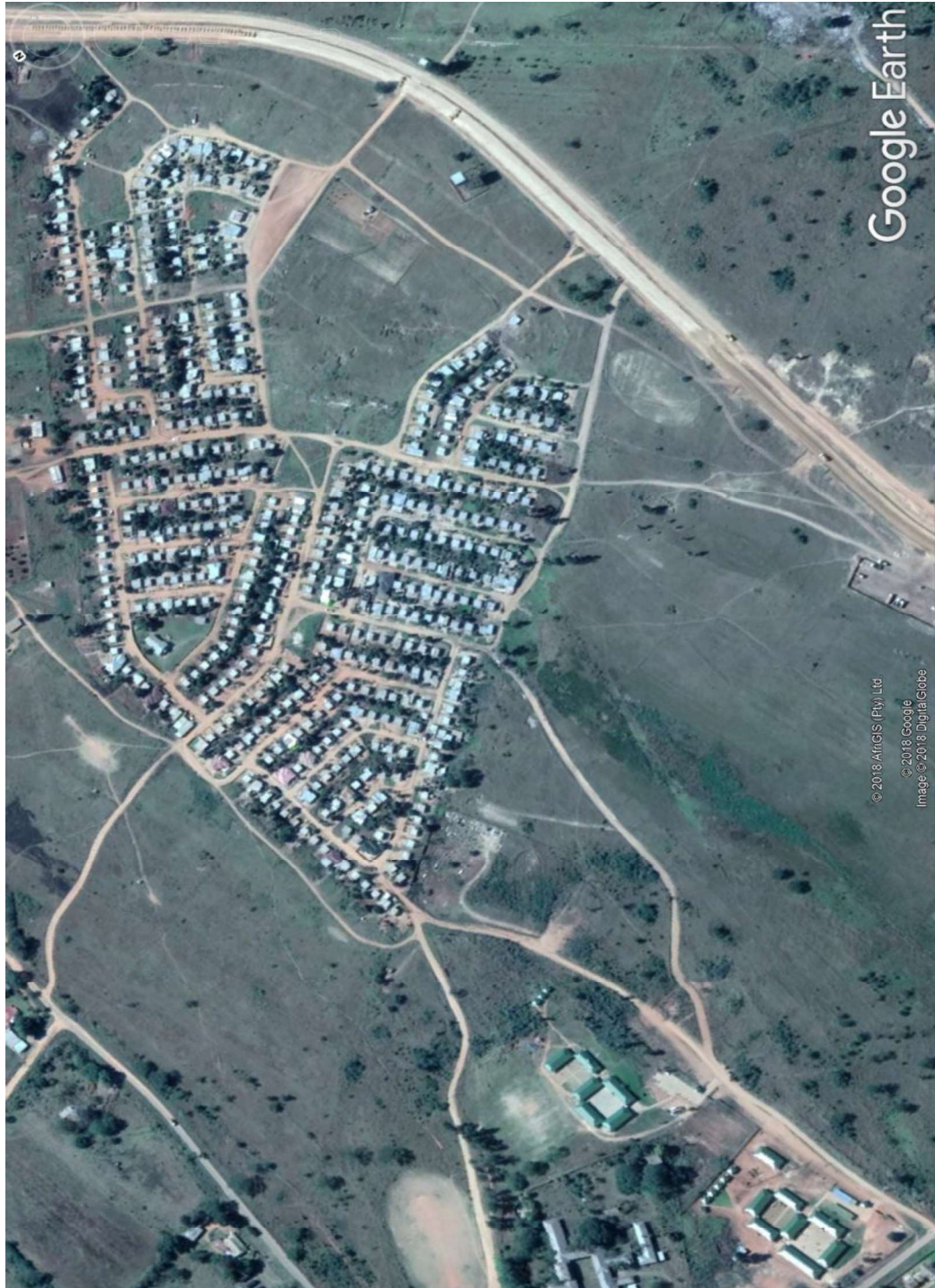

C4.2 : CONSTRUCTION NOTICE BOARD

Details of the Construction Notice Board including fabrication requirements can be found in the book of drawings. Instructions on the erection of the notice board will be done with commencement of the contract and issued by the Engineer on site.

C4.3 : HISTORICAL WEATHER DATA

The information below are given in good faith and the engineer shall not be held accountable for the accuracy thereof. The tender shall assess the information and incorporate the potential risk to delays in the construction period in his programme of works and as stipulated in PART C3: SCOPE OF WORKS Section B12.15.

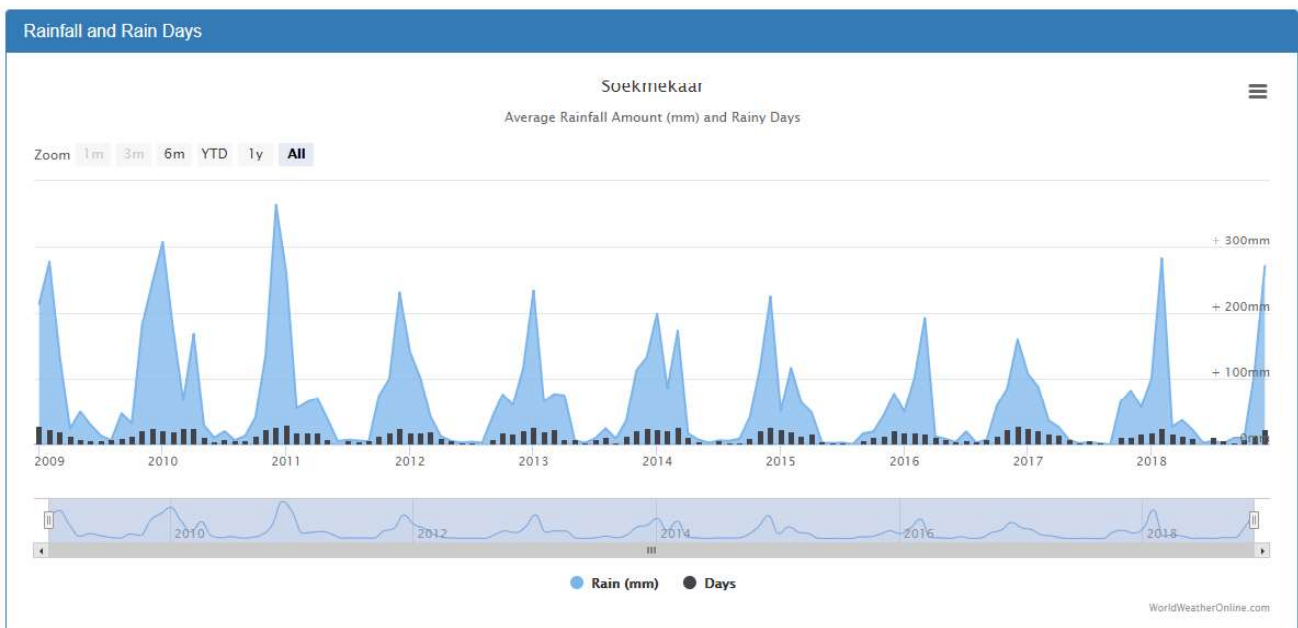
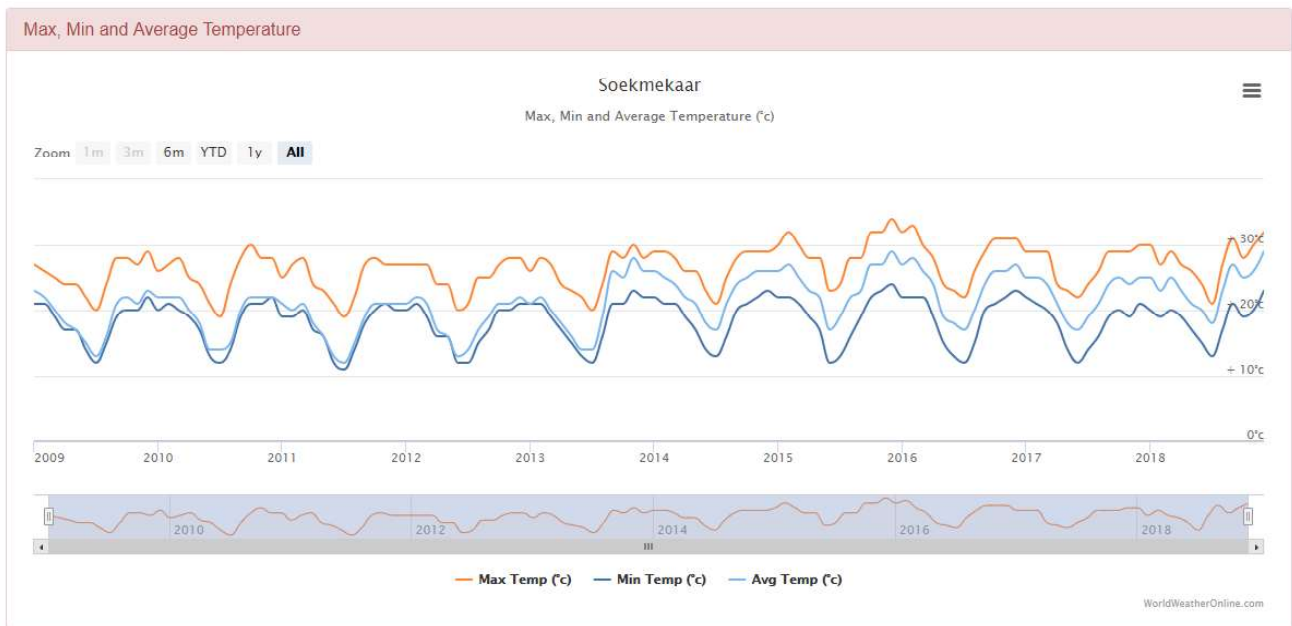

PART C5 : ANNEXURES

C5.1 SCHEDULE OF DRAWINGS

SCHEDULE OF TENDER DRAWINGS

The following drawings included Under Part C5 as attached, form part of this Contract in terms of Clause 2.1 of the General Conditions of Contract. The drawings issued to tenderer's must be regarded as provisional and preliminary for the tenderer's benefit to generally assess the scope of work.

LIST OF CONTRACT DRAWINGS		
DESCRIPTION	DRAWING NO.	STATUS
General Layout of Roads	GL01-GL02	Tender
Stormwater Layouts	SL01-SL02	Tender
Road Longsections	LS01-LS14	Tender
Stormwater Longsections	LSW01-LSW11	Tender
Typical Road Cross Section	Cs00	Tender
Typical Speedhump	TR01	Tender
Typical Road Signs	TR02-TR03	Tender
Typical Kerbing at entrances	TR04	Tender
Typical detail for kerbing	TR05	Tender
Typical Junction Box	TS01	Tender
Typical Inlet Structure	TS02	Tender
Typical Outlet Structure	TS03	Tender
Typical Contract Board	TP01	Tender

The Tenderer shall satisfy him/herself that the set of drawings is complete in accordance with the above schedule, and if any are found missing or duplicated, or the writing or figures indistinct, he/she shall apply to the Engineer immediately and have the discrepancy rectified.

The tenderer's attention is brought to clause 2.4 in the Contract Specific Data pertaining to the ambiguity or discrepancy between the documents.

No liability whatsoever will be admitted by the Employer in respect of errors in tenders attributed to any such discrepancy.

C5.2: CONTRACT DRAWINGS



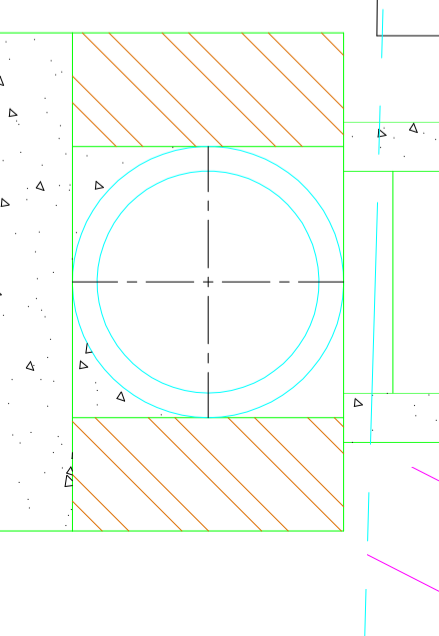
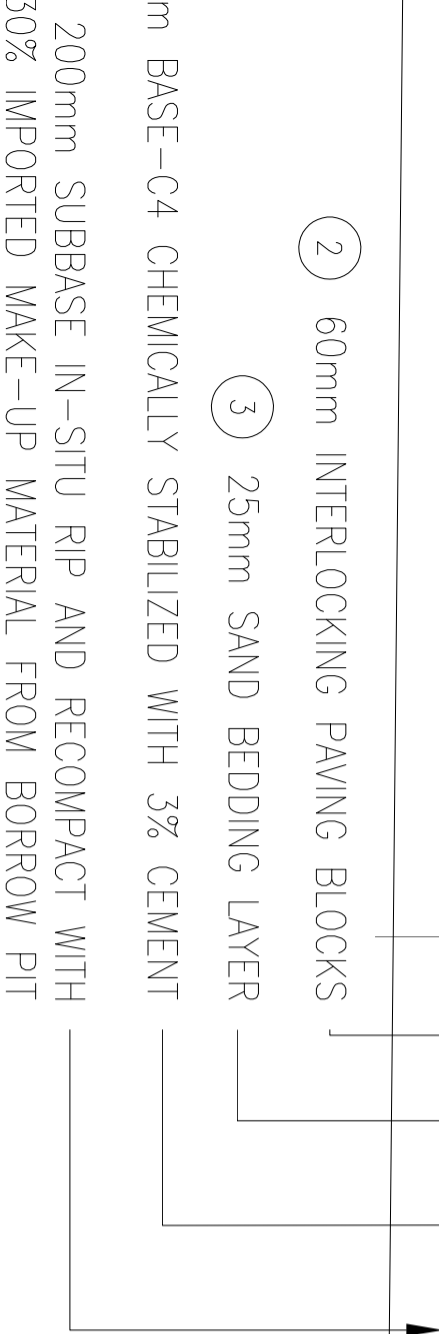

TYPICAL CROSS SECTION

MATERIAL REQUIREMENTS

	TRH 14/ TG 2 TYPE	SECTION OF SPECIFICATION	COMPACTION (% OF MOD AASHTO)	P.I. (MAX)	G.M. (MIN)	CBR AT % AASHTO
AM - NATURAL GROUND	G7	3400	93	3GM+10	1,2	15 @
er	-	SABS	-	-	-	-

8					
-4.917%					
K-value = -7.942					
1167.780					
1167.680					
1167.511					
1167.370					
1167.320					
1167.420					
1167.209					
1167.109					
1167.159	1167.11				
1166.928					
1166.900					
1166.956					
1166.850					
1166.879					
1166.833					
91.006	1166.64				
74.441					

DATUM 1160.00M.S.L.		X-FALL VARS	
VERT ALIGNMENT DATA			
EDGE OF TAR LEVELS		LEFT	RIGHT
CENTRE LINE LEVELS			
GROUND LEVELS			
METREAGE			
HORIZONTAL CURVES			
Straight direction 174.0030 deg. Curve 1 Right Radius 20.00 Straight direction 234.8324 deg.			
0.00	1169.29	1169.307	
19.713		1169.443	
20.00	1169.58	1169.445	
25.00		1169.472	
30.00		1169.487	
35.00		1169.490	
40.00	1169.45	1169.479	
45.00		1169.456	
50.00		1169.421	
55.00		1169.373	
60.00	1169.18	1169.312	
65.00		1169.239	
70.00		1169.153	
75.003		1168.954	
80.00	1168.92	1168.943	
85.00		1168.819	
90.00		1168.680	
95.00		1168.528	
100.00	1168.29	1168.362	
105.00		1168.182	
110.00		1167.988	
115.00		1167.780	
120.00	1167.47	1167.558	
125.00		1167.322	
130.00		1167.072	
135.003		1166.829	
140.00	1166.32	1166.530	
149.713		1165.979	

VERTICAL ALIGNMENT ROAD 4			
FROM CHAINAGE	TO CHAINAGE	GRADE %	K - VALUES
0.000	49.713	0.690	
49.713	109.713	-2.333	-19.846
109.713	149.713		-17.942

120.00	1169.47	1169.386	1169.436	1169.336	
125.00		1169.545	1169.595	1169.495	
130.00		1169.697	1169.747	1169.647	
135.00		1169.832	1169.882	1169.782	
140.00	1169.79	1169.951	1170.001	1169.901	
145.00		1170.055	1170.105	1170.005	
150.00		1170.142	1170.192	1170.092	
155.00		1170.214	1170.264	1170.164	
160.00	1170.13	1170.270	1170.320	1170.220	
165.00		1170.310	1170.360	1170.260	
170.00		1170.334	1170.384	1170.284	
175.00		1170.342	1170.392	1170.292	
180.00	1170.22	1170.334	1170.384	1170.284	
185.00		1170.311	1170.361	1170.261	
200.00	1170.23	1170.216	1170.248	1170.184	
210.186		1170.151	1170.184	1170.119	
220.00	1170.14	1170.089	1170.122	1170.057	
225.00		1170.064	1170.105	1170.023	
230.00		1170.050	1170.100	1170.000	
235.00		1170.049	1170.099	1169.999	
240.00	1170.03	1170.060	1170.110	1170.010	
245.00		1170.083	1170.133	1170.033	
250.00		1170.117	1170.167	1170.067	
255.00		1170.164	1170.214	1170.114	
260.00	1170.13	1170.223	1170.273	1170.173	
265.00		1170.294	1170.344	1170.244	
270.00		1170.377	1170.427	1170.327	
275.00		1170.473	1170.523	1170.423	
280.00	1170.48	1170.580	1170.630	1170.530	
295.00		1170.920	1170.906	1170.934	
300.00	1170.99	1171.025	1170.989	1171.061	
305.00		1171.114	1171.078	1171.150	
310.00		1171.187	1171.151	1171.222	
315.00		1171.243	1171.207	1171.279	
320.00	1171.22	1171.283	1171.247	1171.319	
325.00		1171.306	1171.271	1171.342	
330.00		1171.314	1171.278	1171.350	
335.00		1171.305	1171.262	1171.348	
340.00	1171.25	1171.280	1171.230	1171.330	
345.00		1171.238	1171.188	1171.288	
350.00		1171.180	1171.130	1171.230	
355.00		1171.106	1171.056	1171.156	
360.00	1171.08	1171.024	1170.974	1171.074	
380.00	1170.64	1170.694	1170.644	1170.744	
385.00		1170.614	1170.564	1170.664	
390.00		1170.537	1170.487	1170.587	
395.00		1170.464	1170.414	1170.514	
400.00	1170.40	1170.394	1170.344	1170.444	
405.00		1170.328	1170.278	1170.378	
410.00		1170.266	1170.216	1170.316	
415.00		1170.207	1170.157	1170.257	
420.00	1170.27	1170.152	1170.102	1170.202	
425.00		1170.101	1170.051	1170.151	
430.00		1170.053	1170.003	1170.103	
435.00		1170.010	1169.960	1170.060	
440.00	1170.12	1169.969	1169.919	1170.019	
450.00		1169.892	1169.842	1169.942	
455.00		1169.853	1169.787	1169.920	
460.00	1169.78	1169.813	1169.730	1169.896	
465.00		1169.772	1169.688	1169.855	
470.00		1169.729	1169.646	1169.813	
475.00		1169.686	1169.602	1169.769	
480.00	1169.48	1169.641	1169.557	1169.724	
485.00		1169.595	1169.515	1169.674	
490.00		1169.548	1169.472	1169.623	
495.00		1169.499	1169.424	1169.575	
500.00	1169.48	1169.450	1169.374	1169.526	
505.00		1169.398	1169.322	1169.474	
510.00		1169.341	1169.266	1169.417	
515.00		1169.281	1169.205	1169.356	
520.00	1169.29	1169.215	1169.140	1169.291	
525.00		1169.146	1169.070	1169.222	

60,000 M VC
K-value = -15.734

-0.632%

60,000 M VC
K-value = 20.702

2.267%

60,000 M VC
K-value = -15.331

-1.647%

60,000 M VC
K-value = 68.351

-0.769%

50,000 M VC
K-value = -216.667
-1.000%

50,000

353.9996 deg.
Straight direction

Curve 2 Left
Radius 0.00

353.9983 deg.
Straight direction

Curve 3 Right
Radius 10.00

83.9524 deg.
Straight direction

Curve 4 Right
Radius 10.00

573.9999 deg.
Straight direction

Curve 5 Right
Radius 0.00

174.0000 deg.
Straight direction

Curve 6 Left
Radius 50.00

144.8328 deg.
Straight direction

Curve 7 Right
Radius 0.00

144.8328 deg.
Straight direction

144.8328 deg.
Straight direction

210.186

210.186

233.353

249.053

283.554

299.279

322.468

322.468

391.198

416.651

468.968

468.968

153
151
131
02
34
167
192

55.00		1173.377	1173.327	1173.427
60.00	1172.92	1173.275	1173.225	1173.325
65.00		1173.165	1173.115	1173.215
70.00		1173.047	1172.997	1173.097
75.00		1172.922	1172.872	1172.972
80.00	1172.40	1172.789	1172.739	1172.839
85.00		1172.648	1172.598	1172.698
90.00		1172.500	1172.450	1172.550
95.00		1172.344	1172.294	1172.394
100.00	1171.80	1172.180	1172.130	1172.230
105.00		1172.008	1171.958	1172.058
110.00		1171.829	1171.779	1171.879
115.00		1171.647	1171.645	1171.650
120.00	1170.94	1171.462	1171.507	1171.418
125.00		1171.275	1171.319	1171.230
130.00		1171.084	1171.129	1171.040
135.00		1170.891	1170.936	1170.846
140.00	1170.27	1170.695	1170.740	1170.650
145.00		1170.496	1170.541	1170.452
150.00		1170.295	1170.339	1170.250
155.00		1170.090	1170.137	1170.044
160.00	1169.52	1169.883	1169.931	1169.835
165.00		1169.673	1169.721	1169.625
167.339		1169.574	1169.622	1169.526
180.00	1168.89	1169.035	1169.084	1168.987

60.000 M VC
 K-value = -32.330
 -3.583%
 K-value = -89.552
 -4.253%

Straight direction
 214.0005 deg.
 Curve 1 Right
 Radius 505.00
 127.454
 142.814
 145.634
 142.814
 Curve 2 Right
 Radius 0.00
 234.8318 deg.

GNMENT ROAD 10	
GRADE %	K - VALUES
-1.727	-32.330
-3.583	-89.552
-4.253	

DATUM 1156.00M.S.L.		1156.00
VERT ALIGNMENT DATA		
EDGE OF TAR LEVELS	LEFT	RIGHT
	1169.006	1169.046
	1168.276	1168.401
	1168.103	1168.228
	1167.914	1168.039
	1167.705	1167.830
	1167.478	1167.603
	1167.231	1167.356
	1166.964	1167.089
	1166.679	1166.804
	1166.374	1166.499
	1166.030	1166.193
		1166.112
		1167.48
		1167.293
		1167.027
		1166.741
		1166.436
		1166.36
		1168.15
		1169.00
		1169.026
		1169.714
		1169.71
METREAGE	0.00	20.00
		40.00
		45.00
		50.00
		55.00
		60.00
		65.00
		70.00
		75.00
		80.00
		85.00
HORIZONTAL CURVES		
	54.491	54.491
	Straight direction 234.8365 deg.	
	Curve 1 Right Radius 0.00	

60.000 M VC
 K-value = -12.9
 -3.439%

VERTICAL ALIGNMENT ROAD 11		
FROM CHAINAGE	TO CHAINAGE	GRADE %
0.000	73.108	-3.439
73.108	133.108	-8.083
133.108	193.108	-2.197

Station	1 Left	2 Right	Curve Radius	Grade %	Vertical Curve Data
54.498	0.00			0.667%	60,000 M VC K-value = -12.115
54.498	144.8375 deg.			-4.286%	
55.00					40,000 M VC K-value = 38.621 -3.250% 40,000 M VC K-value = 13.842 -0.720%
60.00	1166.13				
65.00					
70.00					
75.00					
80.00	1166.14				
85.00					
90.00					
95.00					
100.00	1165.90				
105.00					
110.00					
115.00					
120.00	1165.08				
140.00	1164.16				
145.00					
150.00					
155.00					
160.00	1163.29				
165.00					
170.00					
175.00					
180.00	1162.72				
185.00					
190.00					
195.00					
200.00	1162.14				
205.00					
210.00					
215.00					
220.00	1161.97				
231.932	1161.97				

GNMENT ROAD 12	
GRADE %	K - VALUES
-5.657	9.489
0.667	-12.115
-4.286	38.621
-3.250	13.842
-0.720	

DATUM	1155.00M.S.L.	VERT ALIGNMENT DATA	EDGE OF TAR LEVELS	LEFT	RIGHT	CENTRE LINE LEVELS	GROUND LEVELS	METREAGE	HORIZONTAL CURVES
								0.00	
								8.671	
								10.00	
								15.00	
								20.00	
								25.00	
								30.00	
								35.00	
								40.00	
								45.00	
								50.00	
								55.00	
								60.00	
								65.00	
								70.00	
								75.00	
								80.00	
								85.00	
								90.00	
								95.00	
								100.00	
								105.00	
								110.00	
								115.00	
								120.00	
								130.00	
								140.00	
								150.00	
								160.00	
								170.00	
								180.00	
								190.00	
								200.00	
								210.00	
								220.00	
								231.932	

VERTICAL ALIGNMENT ROAD 1		
FROM CHAINAGE	TO CHAINAGE	GRADE
0.000	38.671	-6.92
38.671	88.671	-4.20
88.671	138.671	-1.14

100.00	1174.26	1174.214	1174.143	1174.286	-0.714%	40,000 M VC K-value = 31.111
110.00		1174.143	1174.071	1174.214		
115.00		1174.111	1174.040	1174.183		
120.00	1174.19	1174.087	1174.016	1174.159		
125.00		1174.072	1174.000	1174.143		
130.00		1174.064	1173.993	1174.136		
135.00		1174.065	1173.993	1174.136		
140.00	1174.31	1174.073	1174.002	1174.145		
145.00		1174.090	1174.018	1174.161		
150.00		1174.114	1174.043	1174.186		
160.00	1174.13	1174.171	1174.100	1174.243	0.571%	80,000 M VC K-value = 117.895
165.00		1174.201	1174.130	1174.272		
170.00		1174.233	1174.161	1174.304		
175.00		1174.267	1174.195	1174.338		
180.00	1174.23	1174.303	1174.231	1174.374		
185.00		1174.341	1174.269	1174.412		
190.00		1174.381	1174.310	1174.452		
195.00		1174.423	1174.352	1174.495		
200.00	1174.33	1174.468	1174.396	1174.539		
205.00		1174.514	1174.443	1174.586		
210.00		1174.563	1174.492	1174.635		
215.00		1174.614	1174.543	1174.685		
220.00	1174.40	1174.667	1174.596	1174.738		
225.00	228.188	1174.722	1174.651	1174.793		
230.00	228.188	1174.779	1174.708	1174.851		
235.00		1174.839	1174.767	1174.910		
240.00	1174.65	1174.900	1174.829	1174.971		
260.00	1174.84	1175.150	1175.079	1175.221	1.250%	40,000 M VC K-value = -16.552
265.00		1175.205	1175.134	1175.276		
270.00		1175.245	1175.173	1175.316		
275.00		1175.270	1175.198	1175.341		
280.00	1175.20	1175.279	1175.208	1175.351		
285.00		1175.274	1175.202	1175.345		
290.00		1175.253	1175.182	1175.325		
295.00		1175.217	1175.146	1175.289		
300.00	1175.01	1175.167	1175.095	1175.238		
320.00	1174.83	1174.933	1174.862	1175.005	-1.167%	
325.00		1174.881	1174.809	1174.952		
330.00		1174.840	1174.769	1174.911		
335.00		1174.811	1174.739	1174.882		
340.00	1174.72	1174.793	1174.722	1174.865		
345.00		1174.787	1174.716	1174.859		
350.00		1174.793	1174.722	1174.865		
355.00		1174.811	1174.739	1174.882		
360.00	1174.71	1174.840	1174.769	1174.911		
380.00	1174.98	1174.980			0.700%	

122.7515 deg.
Straight direction

Curve 2 Left
Radius 0.00

122.7506 deg.
Straight direction

Curve 3 Right
Radius 25.00

174.5001 deg.
Straight direction

K - VALUES	
-16.765	
31.111	
117.895	
-16.552	
21.429	

	100.00	1171.64	1171.750	1171.736	1171.764	0.625%
	120.00	1171.40	1171.625	1171.603	1171.647	40,000 M VC K-value = 22.923
	125.00		1171.599	1171.575	1171.623	
	130.00		1171.584	1171.558	1171.611	
	135.00		1171.580	1171.552	1171.609	
	140.00	1171.41	1171.587	1171.557	1171.618	
	145.00		1171.605	1171.573	1171.638	
	150.00		1171.634	1171.599	1171.668	
	155.00		1171.673	1171.637	1171.710	
	160.00	1171.51	1171.724	1171.685	1171.763	1.120%
	180.00	1171.81	1171.948	1171.901	1171.995	
	200.00	1172.04	1172.172	1172.116	1172.228	
	220.00	1172.08	1172.396	1172.332	1172.460	
	240.00	1172.38	1172.620	1172.548	1172.692	
	250.00		1172.732	1172.655	1172.809	
	255.00		1172.780	1172.701	1172.859	
	260.00	1172.70	1172.813	1172.732	1172.894	
	265.00		1172.830	1172.747	1172.913	30,000 M VC K-value = -16.139
	270.00		1172.832	1172.747	1172.917	
	275.00		1172.818	1172.731	1172.906	
	280.00	1172.48	1172.789	1172.700	1172.878	
	300.00	1172.44	1172.641	1172.552	1172.731	-0.739%
	317.241	1172.54	1172.514			

122.7530 deg.
Straight direction

Curve 2 Right
Radius 10.00

235.106
253.214
Straight direction
Radius 50.00
+226.5060 deg.

Curve 3 Right
Radius 50.00

264.909
279.586
Straight direction
243.3246 deg.

— PIPE LEVELS
 - - - GROUND LEVEL
 SCALE: VERTICAL 1:250
 HORIZONTAL 1:1000

DATUM 1163.00mm.S.L.

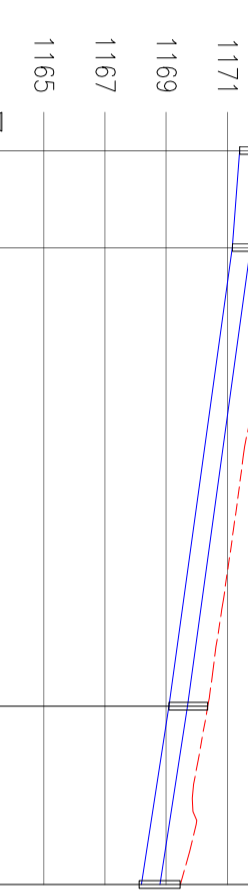

DISTANCE	Hydraulic Design		TO INVERT (m)	INVERT LEVEL	FINAL COVER LEVEL	GROUND LEVEL
	Between points (m)	Accumulated (m)				
DRAINAGE STRUCTURE	ABB1 (KI)	0.00	1.343	1171.397	1172.74	1172.74
	ABB2 (JB)	12.68	1.343	1171.157	1172.50	1172.50
	ABB3 (JB)	20.00	1.266	1169.094	1170.36	1170.36
		40.00	1.341	1168.193	1169.46	1169.46
		60.00	1.341	1168.119	1169.46	1169.46
AB7	95.94	1.341	1168.119	1169.46	1169.46	

600mm dia Concrete OG Class 50D
 Class B Bedding

Hydraulic Design	Design Flow MWWF (l/s)	Proportional Flow %
Construction Gradient %	1.89%	6%
Design Flow MWWF (l/s)	45.00	5%
Proportional Flow %	45.00	4%

DRAINAGE STRUCTURE

ABB1 (KI)
 ABB2 (JB)
 ABB3 (JB)
 AB7

AE4 (JB)	117.90					1.374	1163.976	1165.35	1165.35
A15	140.00	57.13	12%	130.00	4.47%				1164.48
	160.00							1163.74	
	175.03					1.782	1161.423	1163.13	1163.13

DRAINAGE STRUCTURE		AEA1 (KI)	AE4
DISTANCE	Between points (m)	27.55	
	Accumulated (m)	20.00	27.55
Hydraulic Design			
Proportional Flow %		6%	
Design Flow MWWF (l/s)		59.00	
Construction Gradient %		3.21%	
Bedding Class (SABS 1200LB)		Class B Bedding	
Pipe Diameter		600mm dia Concrete OG Class 50D	
EXCAVATION DEPTH TO INVERT (m)		1.204	1.374
INVERT LEVEL		1164.936	1164.051
FINAL COVER LEVEL		1166.14	1165.35
GROUND LEVEL		1166.14	1165.57
DATUM		1159.00m.M.S.L.	

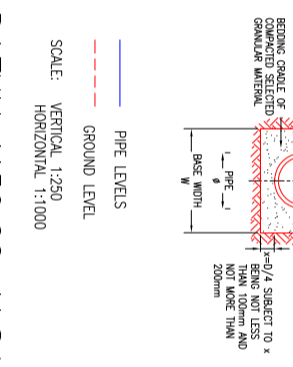

1169	
1167	
1165	
1163	
1161	

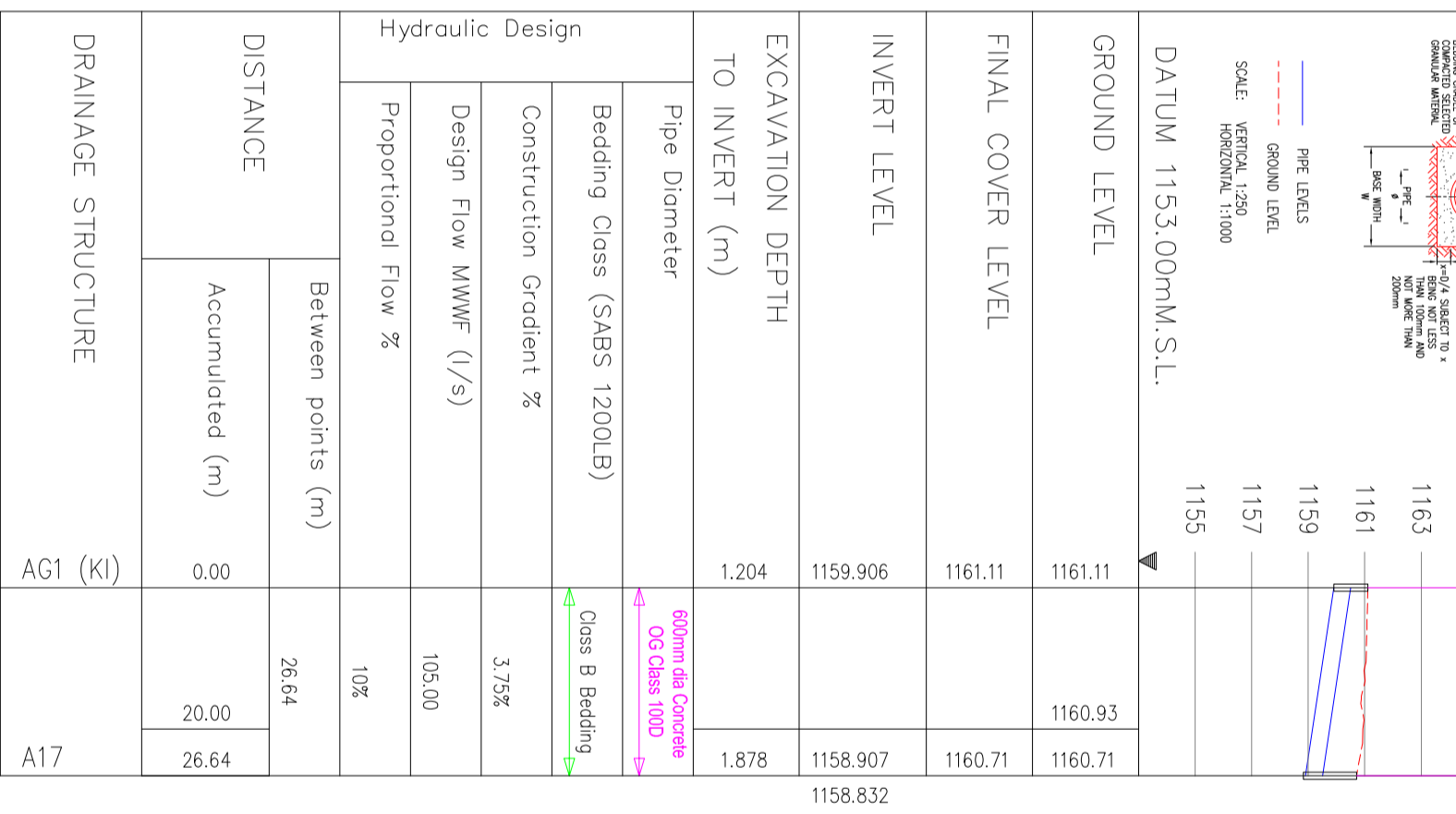
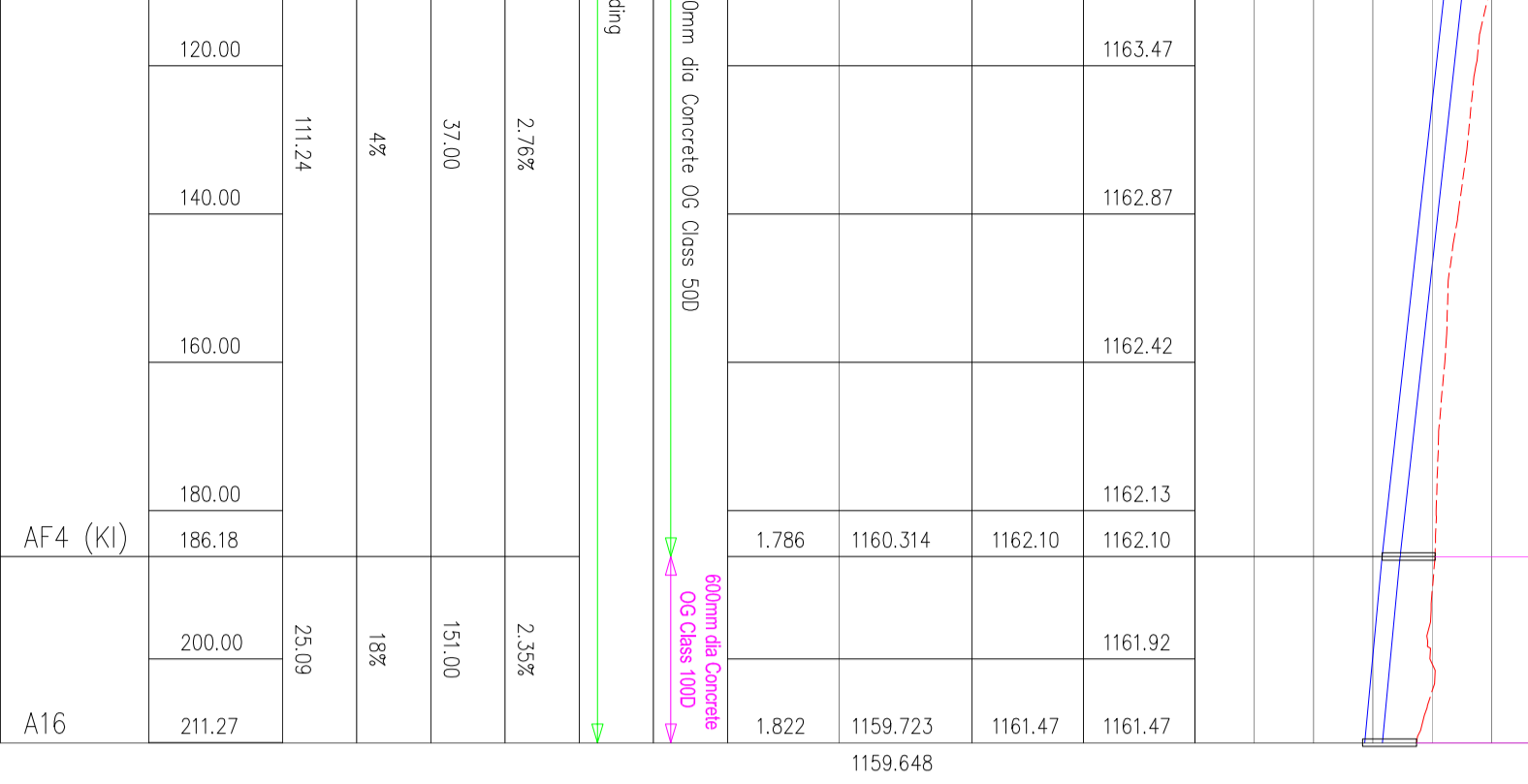

DRAINAGE STRUCTURE		AG1 (KI)	A17
DISTANCE	Between points (m)	26.64	
	Accumulated (m)	20.00	26.64
Hydraulic Design			
Pipe Diameter			
600mm dia Concrete OG Class 100D			
Bedding Class (SABS 1200LB)			
Class B Bedding			
Construction Gradient %			
3.75%			
Design Flow MWWF (l/s)			
105.00			
Proportional Flow %			
10%			

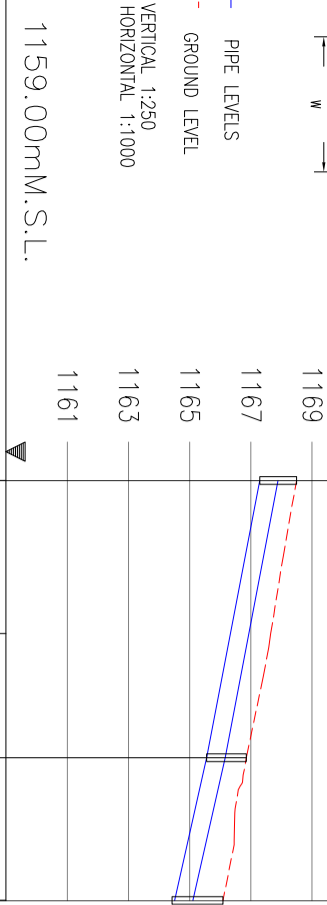

PIPE LEVELS		1169
GROUND LEVEL		1167
VERTICAL 1:250		1165
HORIZONTAL 1:1000		1163
1159.00mm.S.L.		1161
LEVEL	1168.49	1167.65
COVER LEVEL	1168.49	1166.85
LEVEL	1167.290	1166.85
INVERSION DEPTH	1.200	1165.558
INVERSION DEPTH	1.292	1164.505
INVERSION DEPTH	1.660	1164.430
PIPE DIAMETER	600 mm dia Concrete OG Class 50D	
PIPE CLASS (SABS 1200LB)	Class B Bedding	
CONSTRUCTION GRADIENT %	4.78%	5.64%
DESIGN FLOW MWWF (l/s)	62.00	102.00
PROPORTIONAL FLOW %	8%	8%
INVERT POINTS	BETWEEN POINTS (m)	36.24
	ACCUMULATED (m)	20.00
INVERT POINTS	0.00	36.24
	AHB1 (KI)	AHB2 (KI)
	AH9	54.90

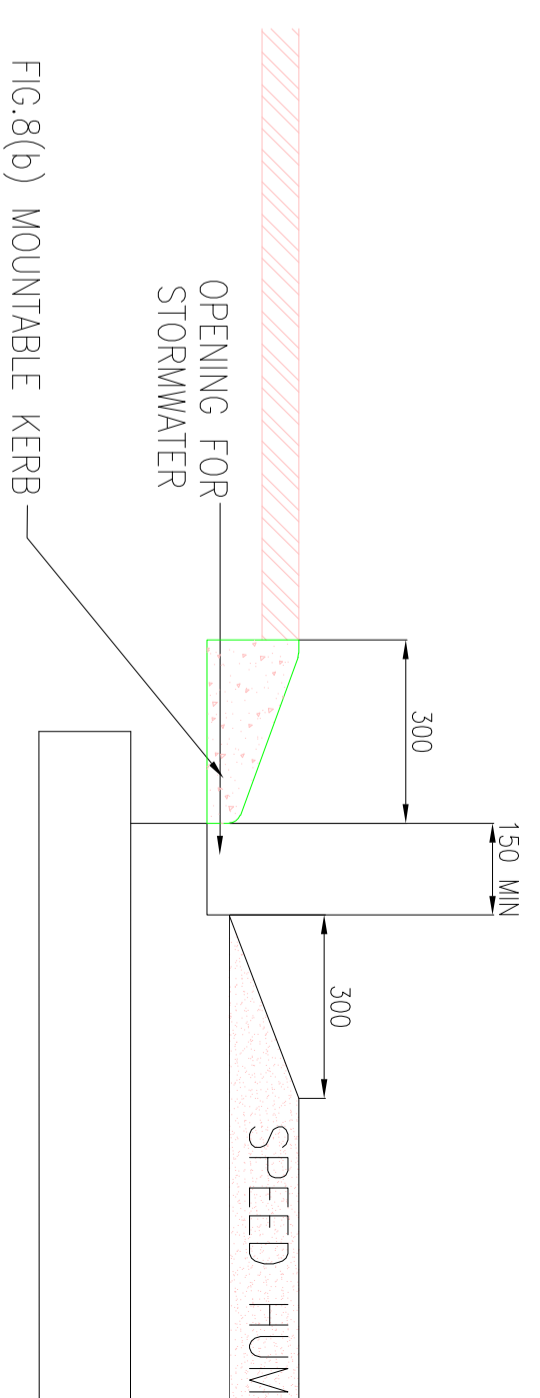
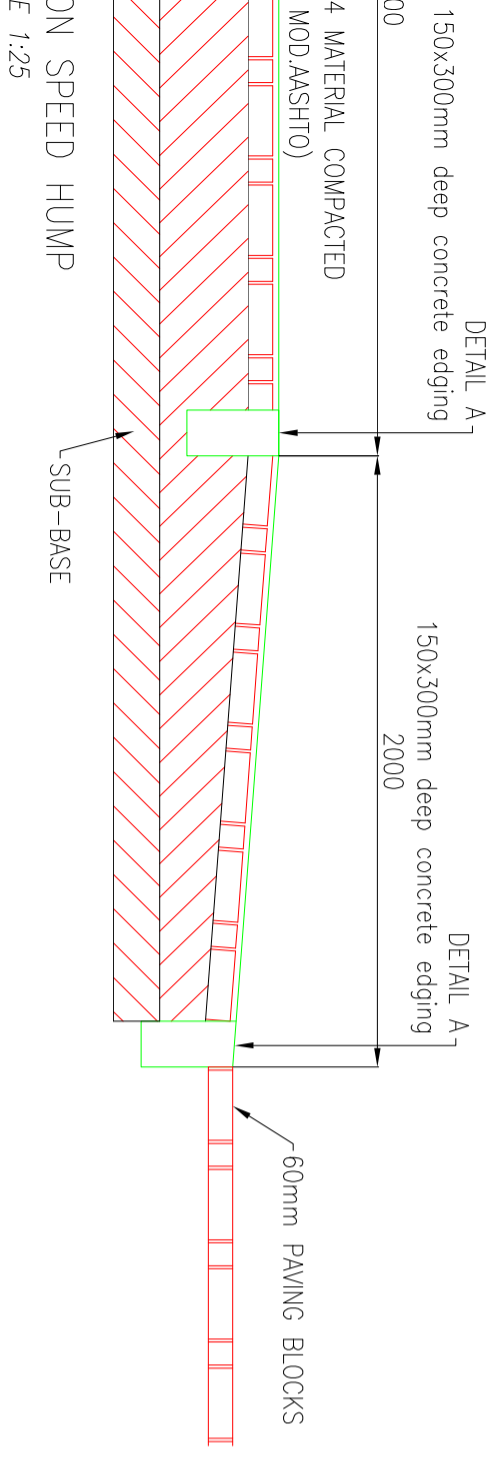
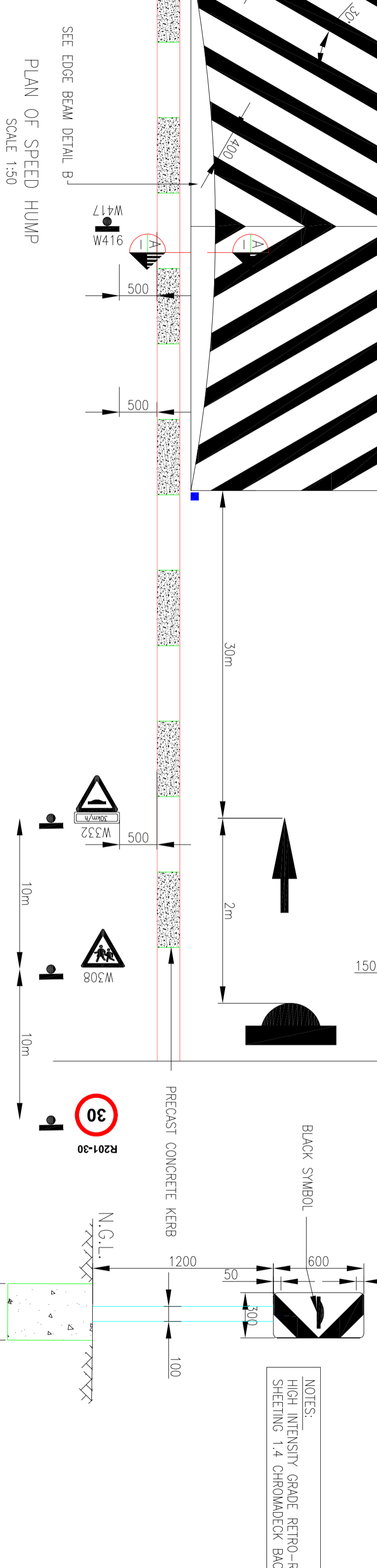

NGTH	TOTAL NUM- BER	MARK	S C	B E N D I N G				
				A	B	C	D	E/r
5900	16	A	20	(5900)				
850	84	SA1	60	250	100			
3750	4	B	62	1750	150	(2010)		
3750	4	C	62	1750	150	(2010)		
850	48	SA1	60	250	100			
	25	32	40	TOT				
				44	Date	6/2/2017		
				110	Det. by	J Hottingh		
				155	Ref Dwg			
					Job No			
					Revision			
					Schedule No			

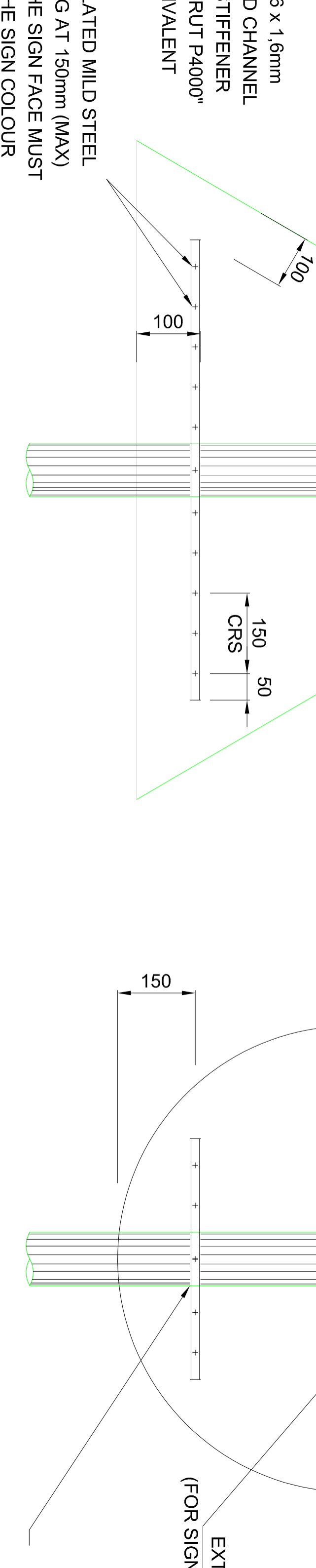

REAR ELEVATION

REAR ELEVATION

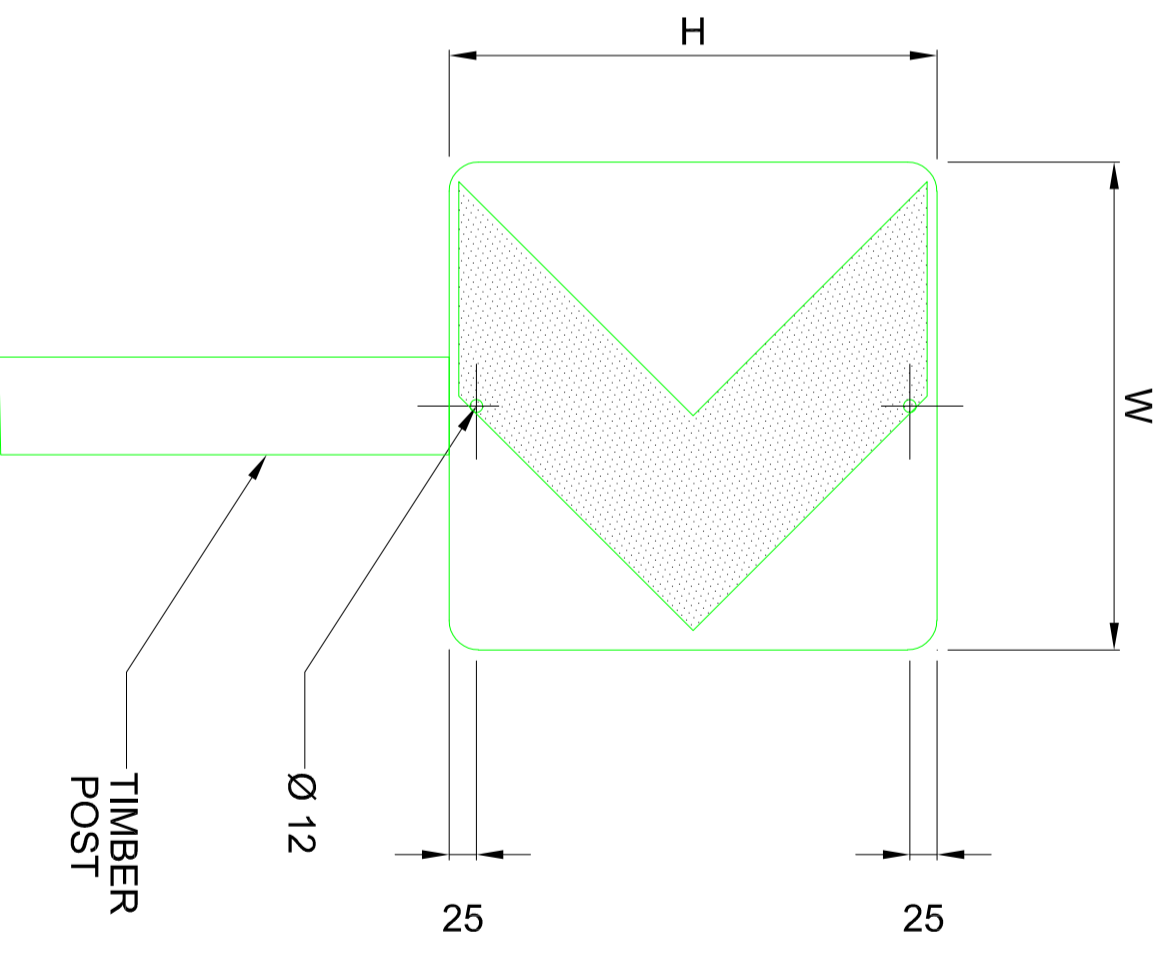
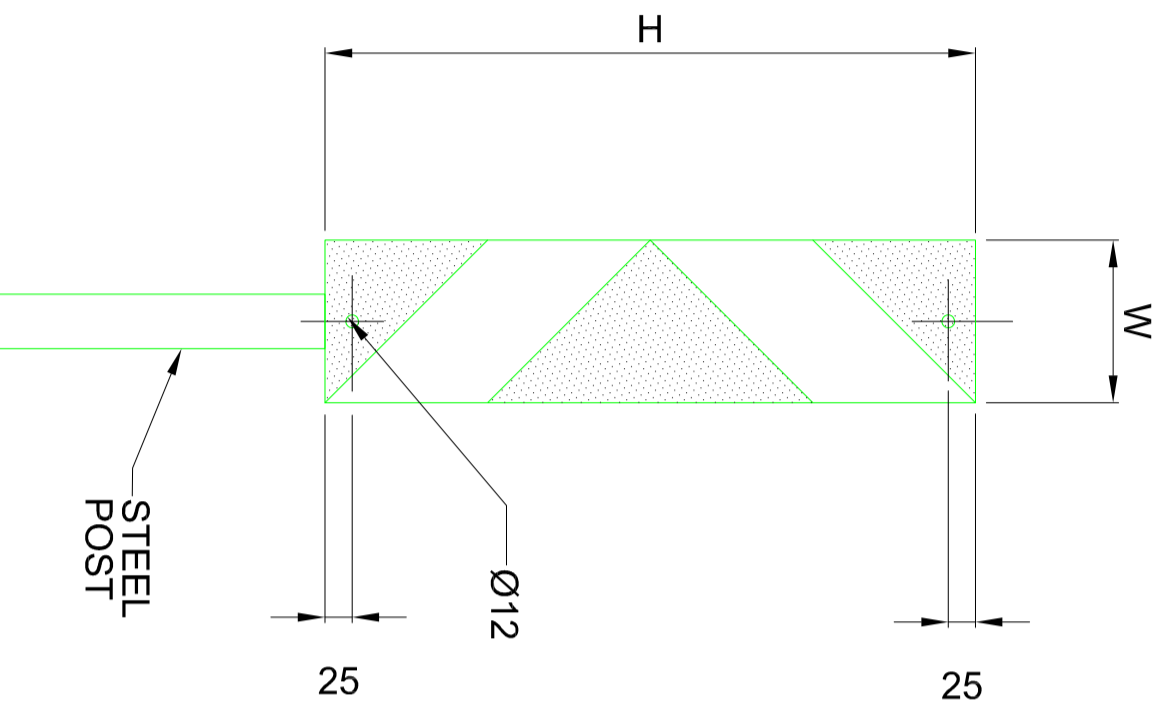
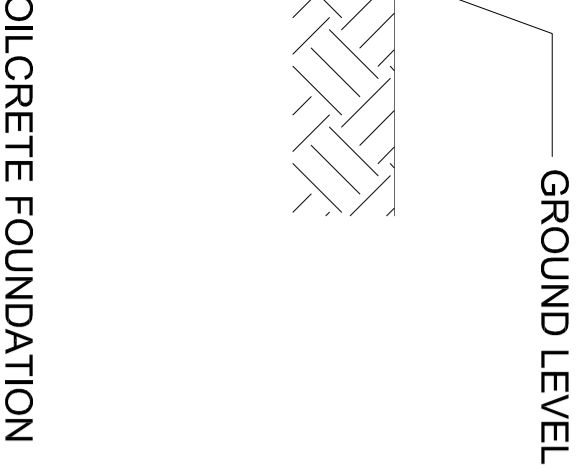

NOTES :

THE ROAD SIGN FACES SHALL BE THE FOLLOWING REQUIREMENTS

1. DETAILS ON THIS DRAWING A SMALLER THAN 1,5m² REQUIR

OPERATING SPEED (km/h)
120
100
80
60

REINFORCEMENT FOR CIRCULAR ROAD SIGNS

SCALE 1 : 20

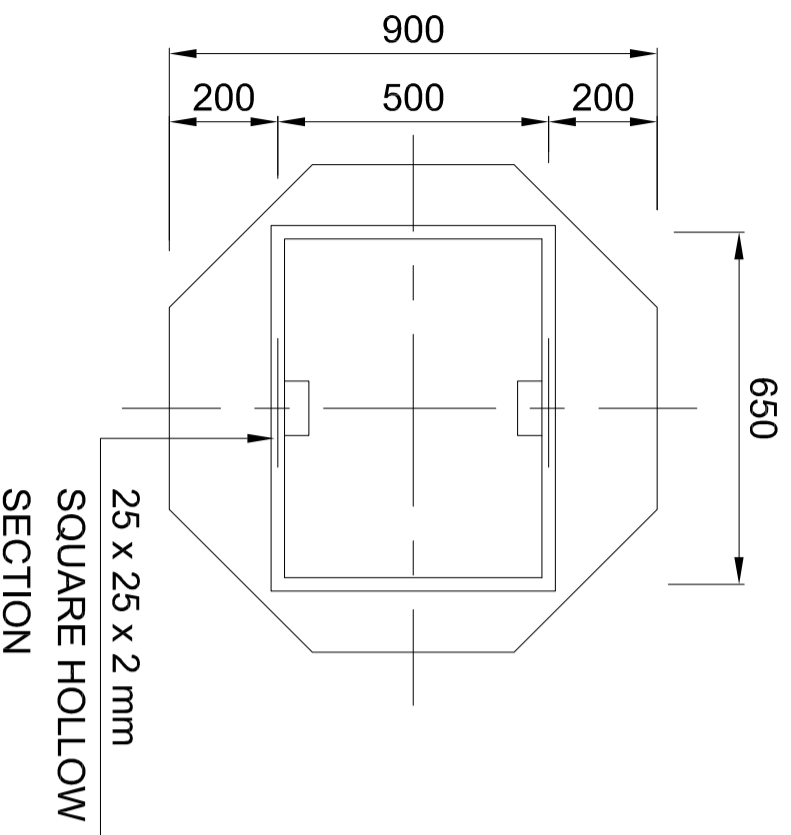

SINGLE SUPPORT

REINFORCEMENT FOR STOP SIGNS

SCALE 1 : 20

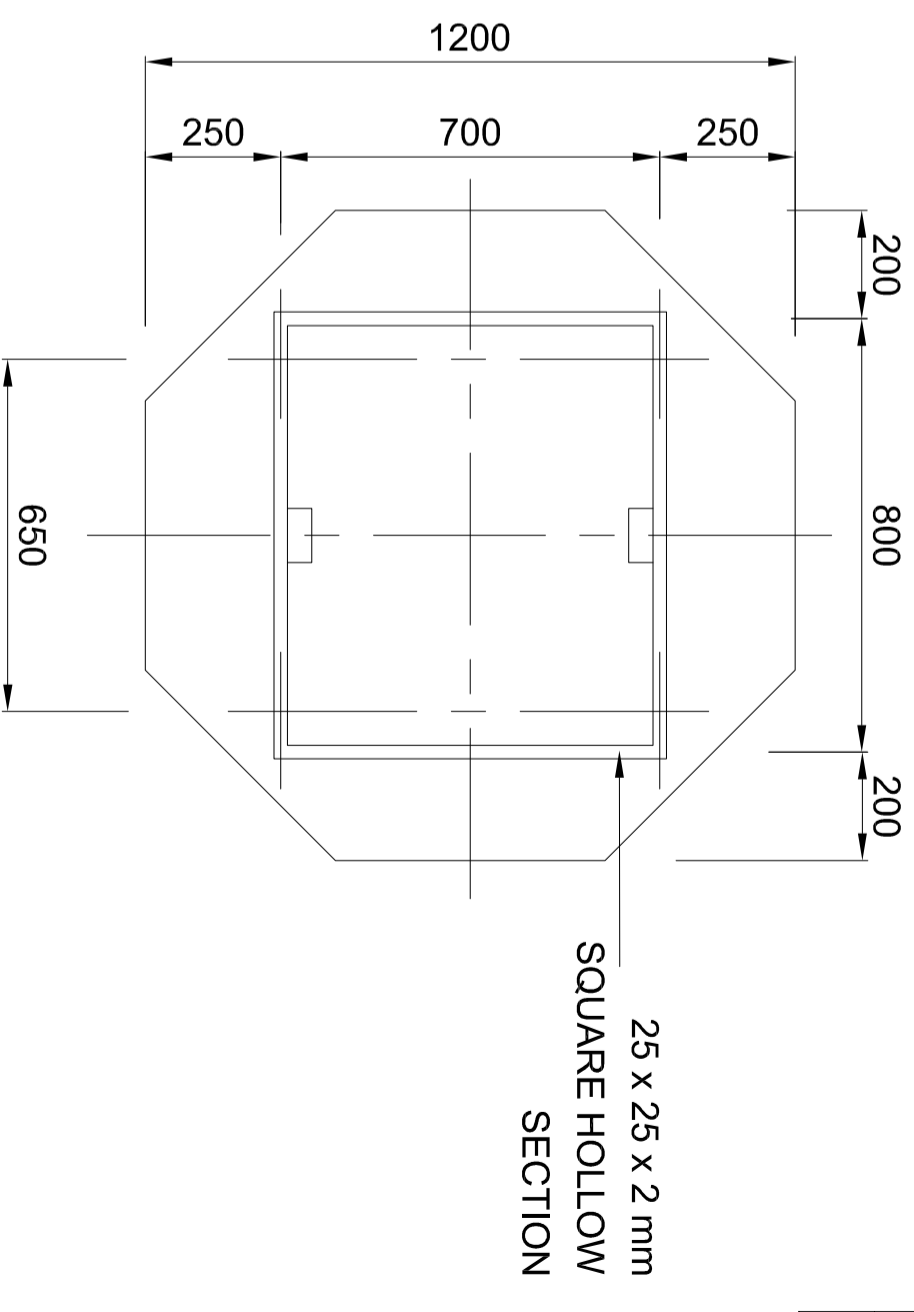
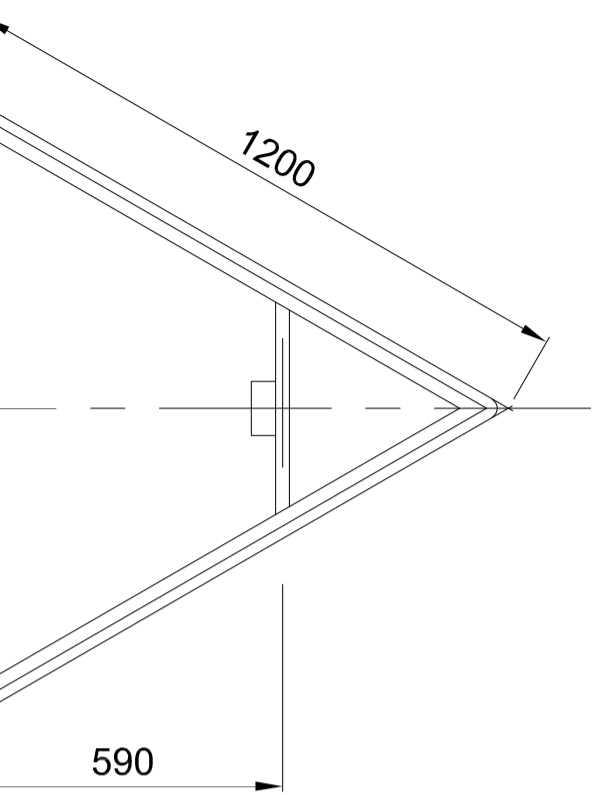

DOUBLE SUPPORT

NOTE:

MINIMUM SIZE FOR
ERECTION BRACKETS
ON R/W SIGNS :

└ 45 x 45 x 6
LENGTH : 100mm

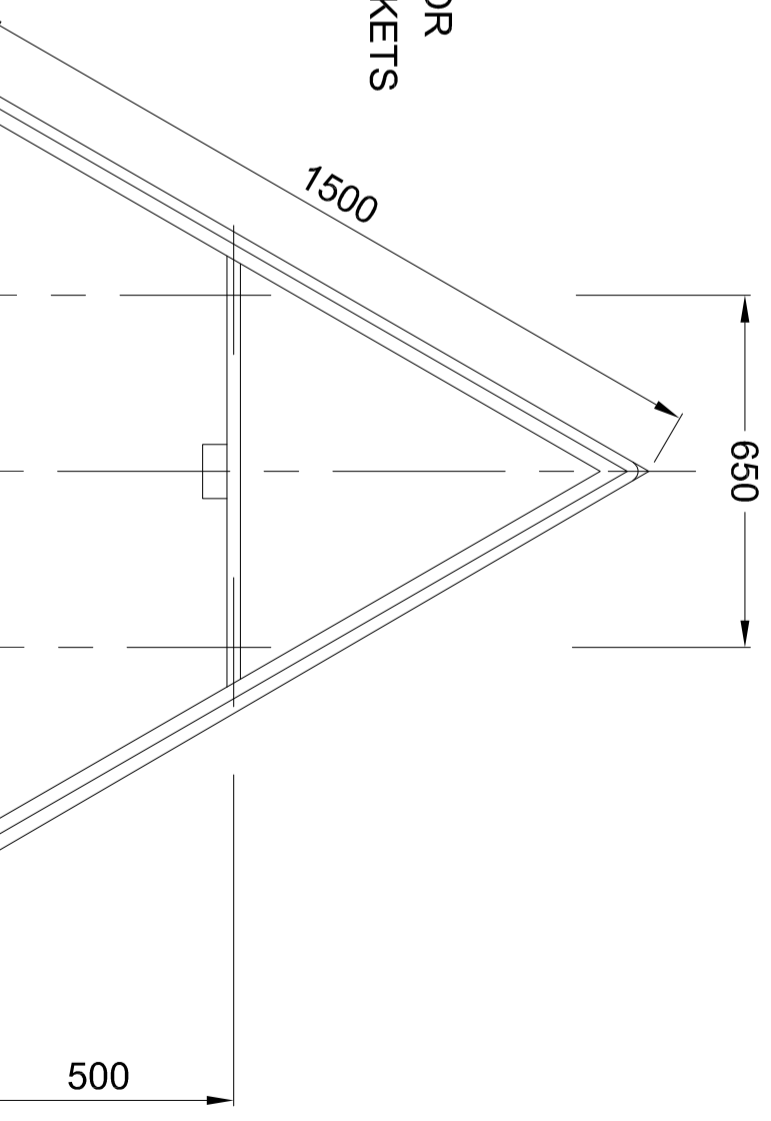

NOTES :

1. DETAILS WITH THE ROAD
2. STRUCTURE REQUIRE AND SPE QUALITY ACCORD

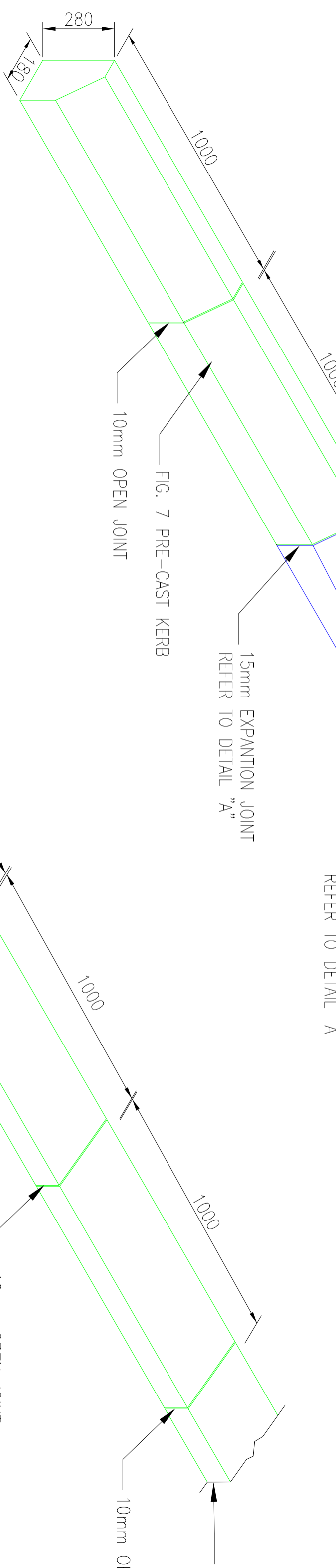

(DRIVEWAY KERBING / EDGE RESTRAINT)

ILLUSTRATION OF TRANSITION KERB BETWEEN FIG. 7 & FIG. 14
(AS DIRECTED BY ENGINEER)

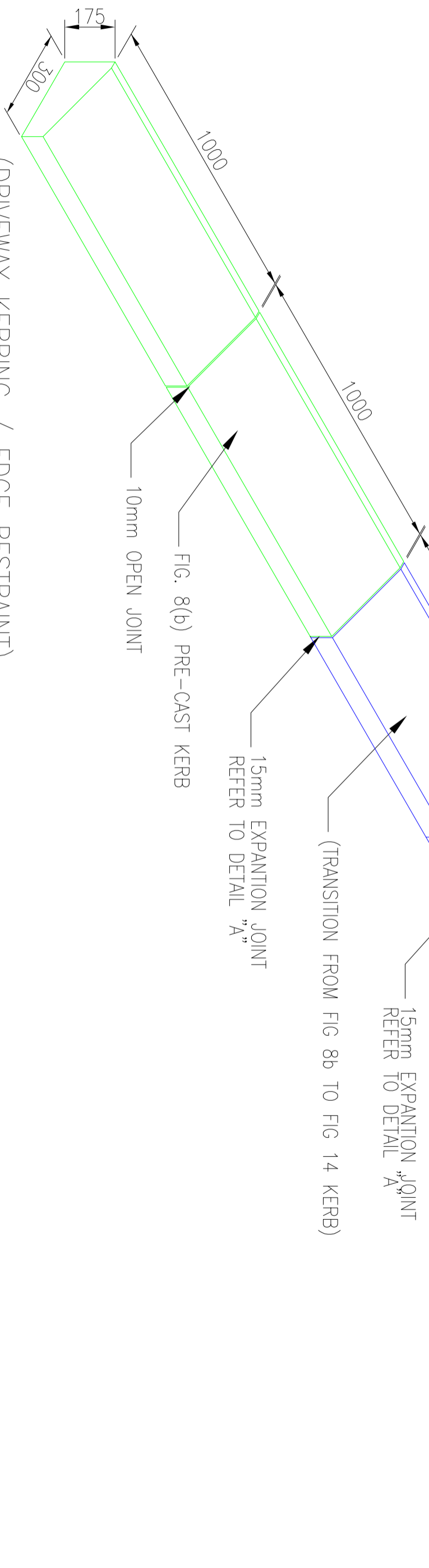

(DRIVEWAY KERBING / EDGE RESTRAINT)

ILLUSTRATION OF TRANSITION KERB BETWEEN FIG. 8(b) & FIG. 14
(AS DIRECTED BY ENGINEER)

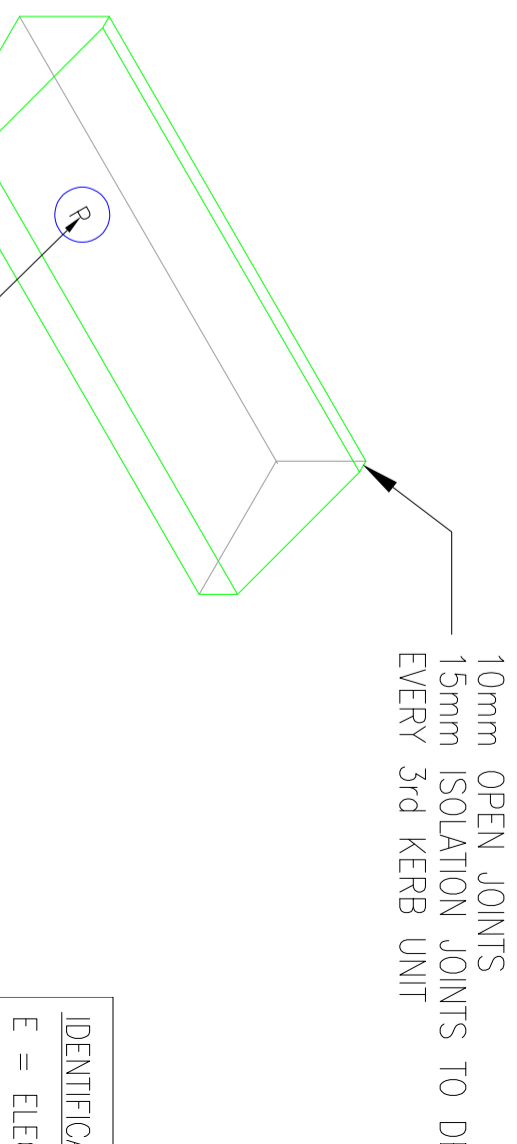

10mm OPEN JOINTS
15mm ISOLATION JOINTS TO D
EVERY 3rd KERB UNIT

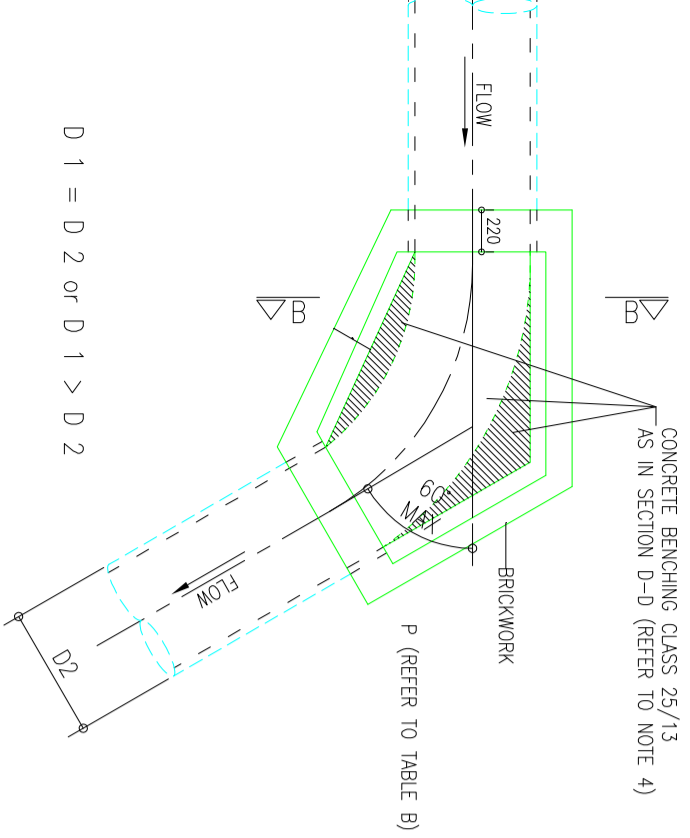
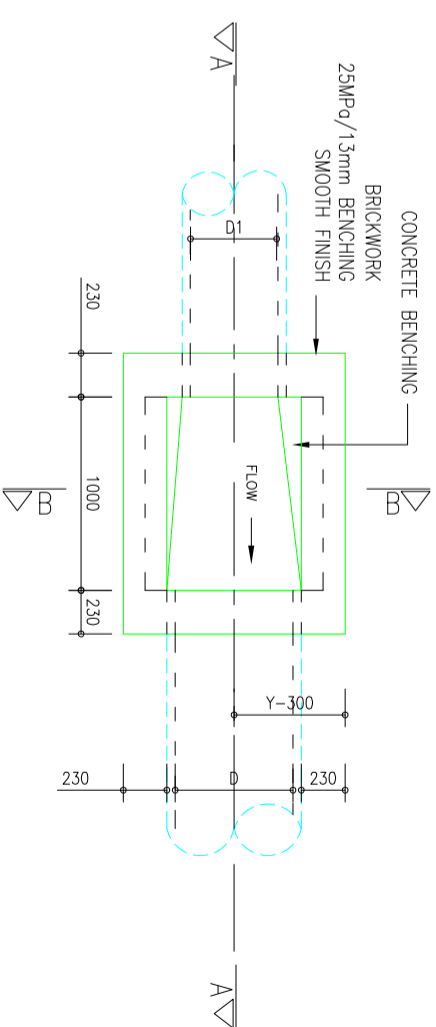
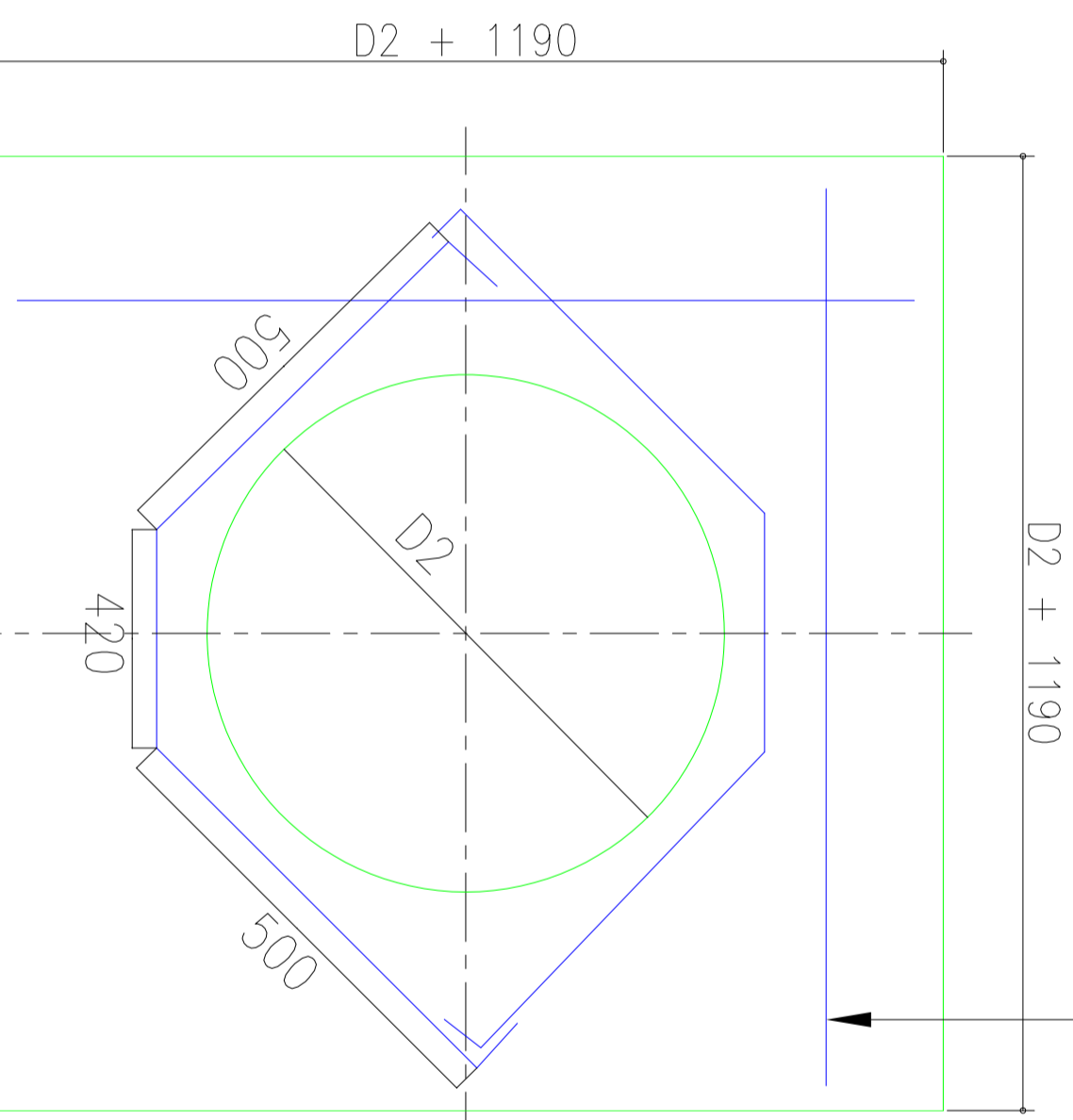

TABLE B

D 2 DIAMETER OF DOWN STREAM PIPE	DISTANCE P
450	700
525	700
600	750
675	780
750	800
825	825
900	850
1050	870
1200	925
1350	1000
1500	1100



- IN SITU CONCRETE COVER SLAB
REINFORCED AS PER COVER SLAB DRAWING
- BRICKWORK WITH BRICKFORCE EVERY 3RD LAYER
- REINFORCED CONCRETE INFILL (REF 617)



BAR No.	DIA	No.	CUT LENGTH
05	Y10	4	980
06	Y10	2	1160
07	Y10	2	1500

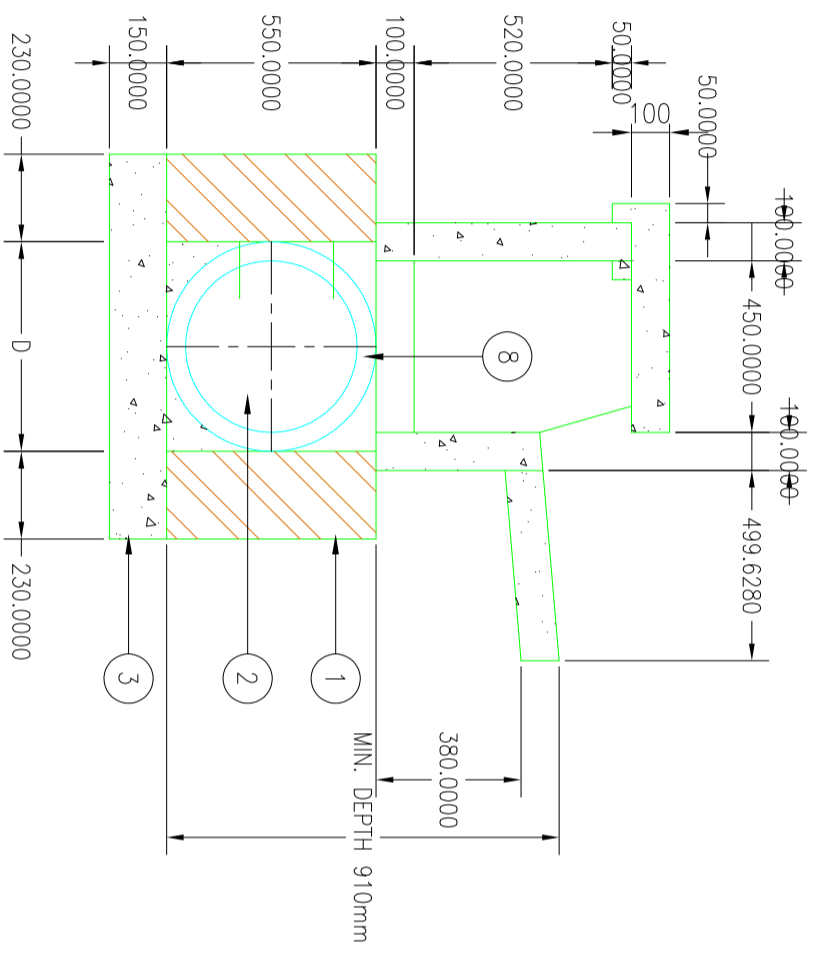
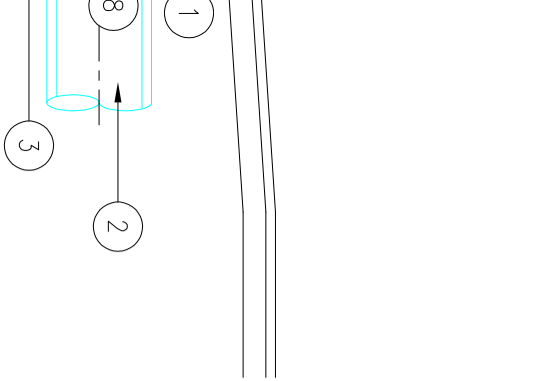

SECTION A:A
SCALE 1:20

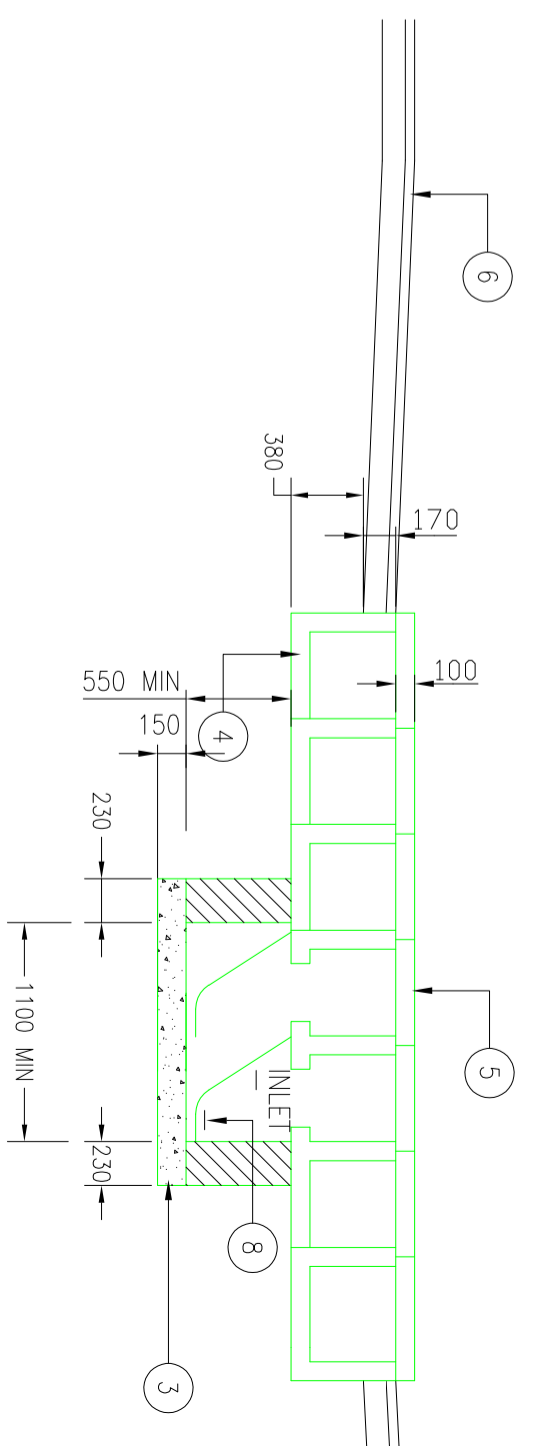

PRECAST KERBMASTER CATCHPIT AT LOW POINTS
FRONT ELEVATION TYPE 2
N.T.S.

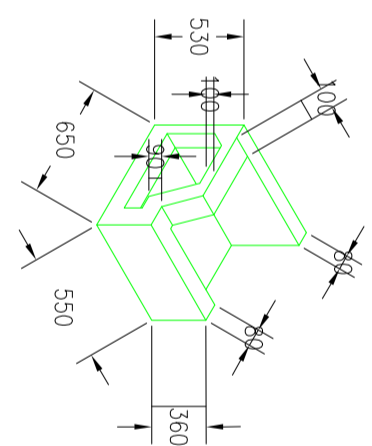
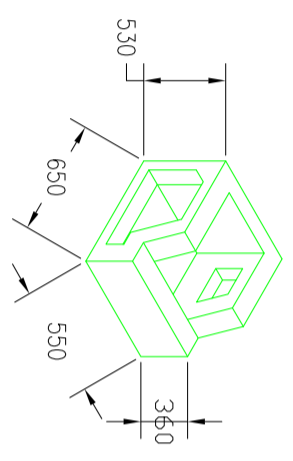
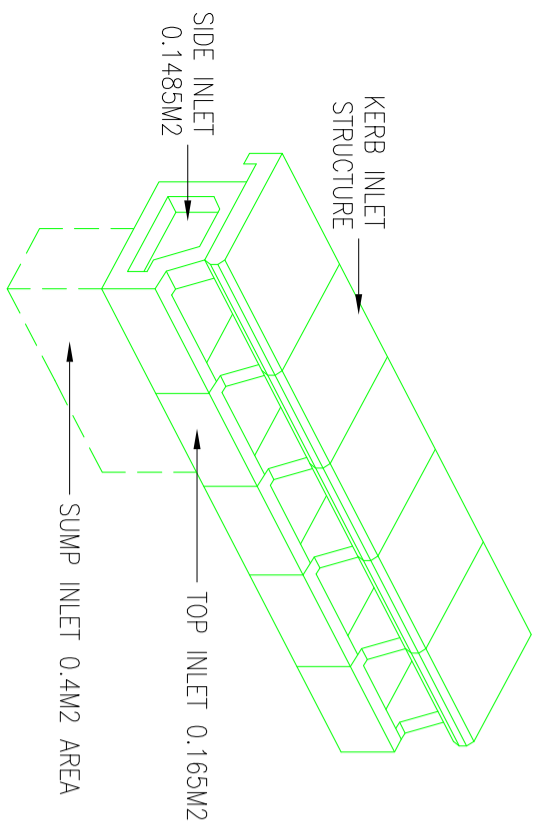

ISOMETRIC VIEW OF KERB INLET - COMPONENTS
N.T.S.

KERB DONE
PORTAR MIX
RB
WITH CHUTE FROM 15MPa SHAPED TO
OF MAIN STORMWATER PIPE

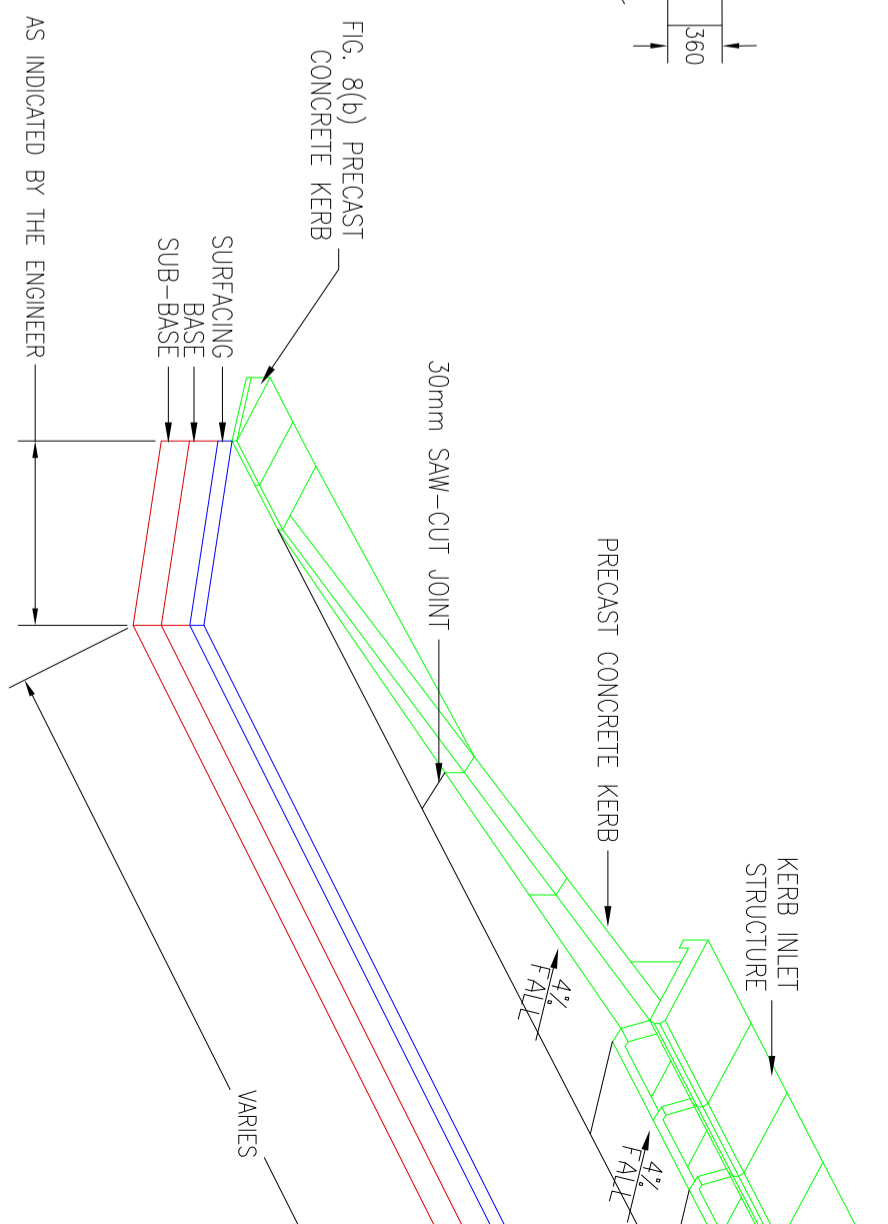

ISOMETRIC VIEW OF KERB INLET
AS INDICATED BY THE ENGINEER

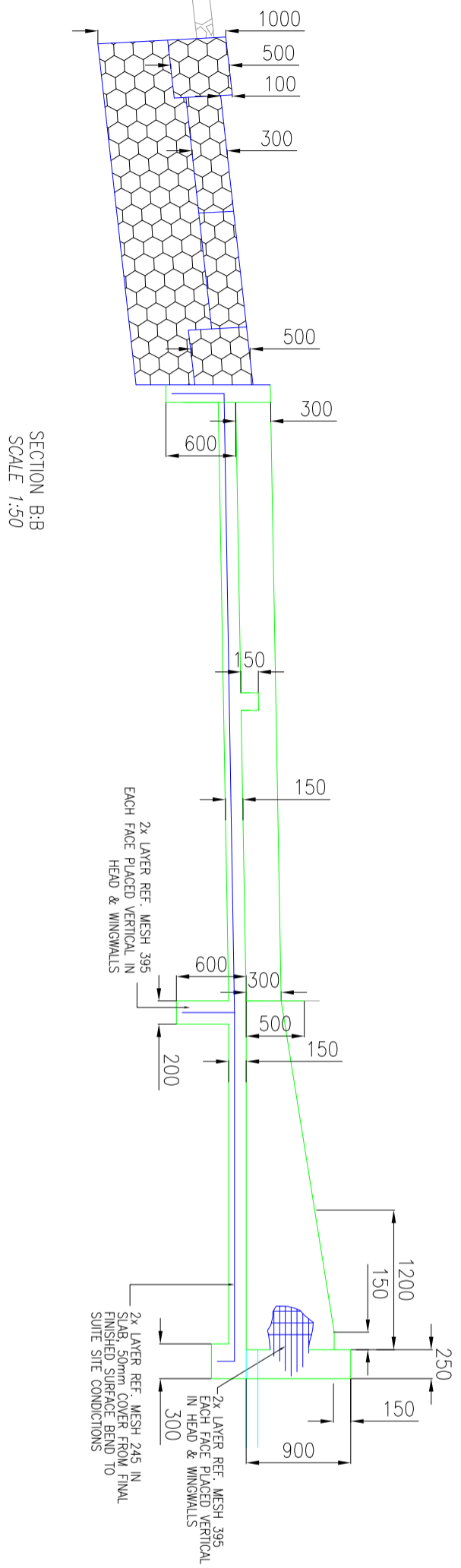
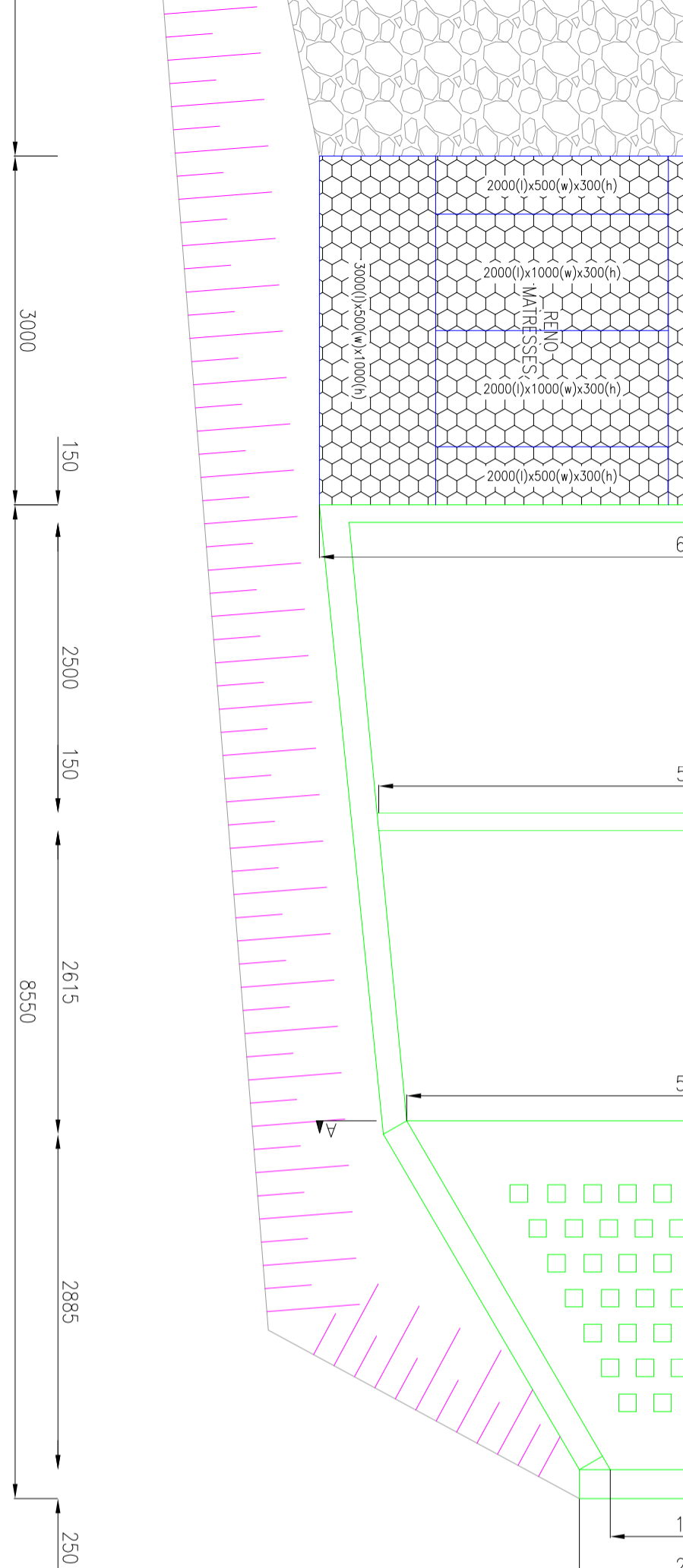

- 2) EXTENT OF PITCHING AND ARMORFLX TO BE INSTRUCTED BY THE ENGINEER.
- 3) WHERE REQUIRED BY THE ENGINEER, MITRE BANKS SHALL BE DOWNSTREAM FROM THE CULVERTS.
- 4) THE UPPER LEVEL OF THE FILL ALWAYS PASSES THROUGH A PORTAL BUILT INTO THE SAME HEAD WALL. DIMENSION B SHALL BE THE DISTANCE BETWEEN THE INTERNAL WALLS OF THE EXTERNAL CULVERT OUTLET SHALL BE 1:1.5.
- 10) F = SLOPE OF CULVERT x 1.5 x (D+W).
- 11) NO BERM SHALL BE CONSTRUCTED WHERE THE SIDE-DRAIN INLET IS AT THE LOWEST POINT.
- 12) WHERE THE TOP OF THE HEADWALL IS LESS THAN 500mm BELOW BREAKPOINT OF THE ROAD, THE TOP OF THE WALL SHALL BE THE SAME LONGITUDINAL GRADIENT AS THAT OF THE ROAD.
- 13) EXTENT OF PITCHING AND ARMORFLX TO BE INSTRUCTED BY THE ENGINEER.
- 4) THE UPPER LEVEL OF THE FILL ALWAYS PASSES THROUGH A PORTAL BUILT INTO THE SAME HEAD WALL. DIMENSION B SHALL BE THE DISTANCE BETWEEN THE INTERNAL WALLS OF THE EXTERNAL CULVERT OUTLET SHALL BE 1:1.5.
- 5) REINFORCEMENT IN WING WALLS AND HEADWALLS FOR INLET AND STRUCTURES IF D EXCEEDS 850 (6.3 DIA - 200 x 200) ON THE FRONT OF WALLS - NO 395 (6.0 DIA - 200 x 200) ON THE REAR OF WALLS - NO 395 (6.0 DIA - 200 x 200) WITH 600mm BASE FOOTING LENGTHS IN BOTH CASES.
- 6) SEE DRAWING NO NKPO09-10100-10103 AND 10112 OF THE FOR THE POSITIONS OF INLETS AND OUTLETS.
- 7) MINIMUM CONCRETE COVER OVER REINFORCEMENT (IF REQUIRED) 20mm AND MAXIMUM CONCRETE COVER 40mm.
- 8) WHERE MORE THAN ONE CONCRETE PIPE CULVERT OR PORTAL BUILT INTO THE SAME HEAD WALL, DIMENSION B SHALL BE THE DISTANCE BETWEEN THE INTERNAL WALLS OF THE EXTERNAL CULVERT OUTLET SHALL BE 1:1.5.
- 9) THE MAXIMUM SLOPE OF EARTHWORKS SURROUNDING A CULVERT OUTLET SHALL BE 1:1.5.
- 10) F = SLOPE OF CULVERT x 1.5 x (D+W).
- 11) NO BERM SHALL BE CONSTRUCTED WHERE THE SIDE-DRAIN INLET IS AT THE LOWEST POINT.
- 12) WHERE THE TOP OF THE HEADWALL IS LESS THAN 500mm BELOW BREAKPOINT OF THE ROAD, THE TOP OF THE WALL SHALL BE THE SAME LONGITUDINAL GRADIENT AS THAT OF THE ROAD.
- 13) EXTENT OF PITCHING AND ARMORFLX TO BE INSTRUCTED BY THE ENGINEER.

